

1601/104
1602/104
TECHNICAL DRAWING I
June/July 2014
Time: 3 hours

LEWIS KUPITA

205101031

easytv.com



THE KENYA NATIONAL EXAMINATIONS COUNCIL

CRAFT CERTIFICATE IN ELECTRICAL AND ELECTRONICS
ENGINEERING
MODULE I
(POWER OPTION)
(TELECOMMUNICATION OPTION)

TECHNICAL DRAWING I

3 hours

INSTRUCTIONS TO THE CANDIDATE

Candidates should have the following for this examination:

Drawing instruments;

Drawing papers.

Answer any FIVE of the following EIGHT questions.

All questions carry equal marks.

Maximum marks for each part of a question are indicated.

DO NOT remove any pages from this booklet.

Candidates should answer the questions in English.

09 SEP 2014

For Examiner's Use Only

Question	1	2	3	4	5	6	7	8	TOTAL SCORE
Candidate's Score									

This paper consists of 9 printed pages.

Candidates should check the question paper to ascertain that all the pages are printed as indicated and that no questions are missing.

1. Figure 1 shows a pictorial drawing of a machined object. Draw full size in first angle projection the following views:
- a front elevation in the direction of arrow F;
 - an end elevation in the direction of arrow E;
 - a plan in direction of arrow P.

Indicate six major dimensions.

(20 marks)

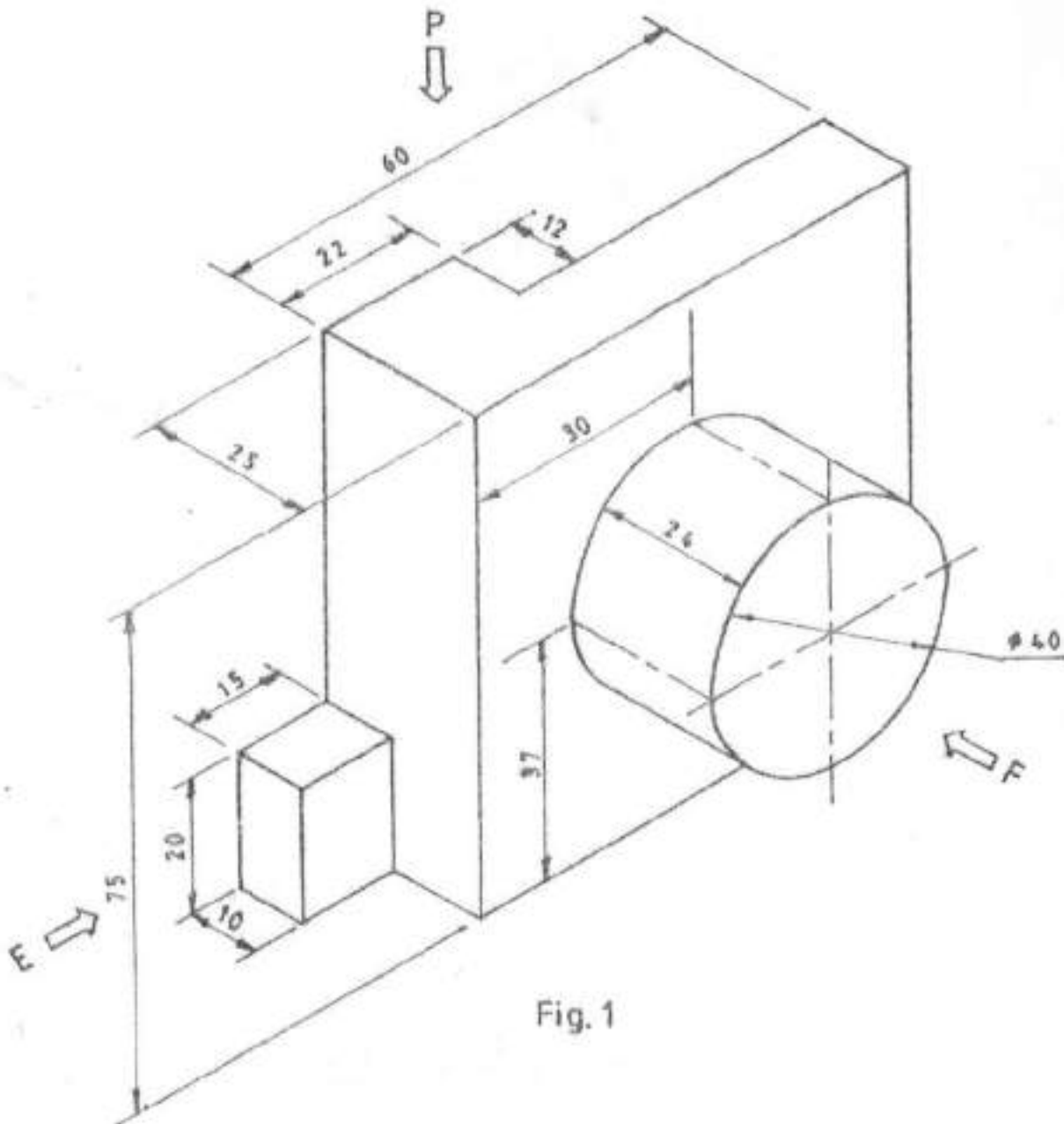

2. Figure 2 shows two views of a solid drawn in 3rd angle projection. Draw an isometric view of the object making corner X the lowest point.

(20 marks)

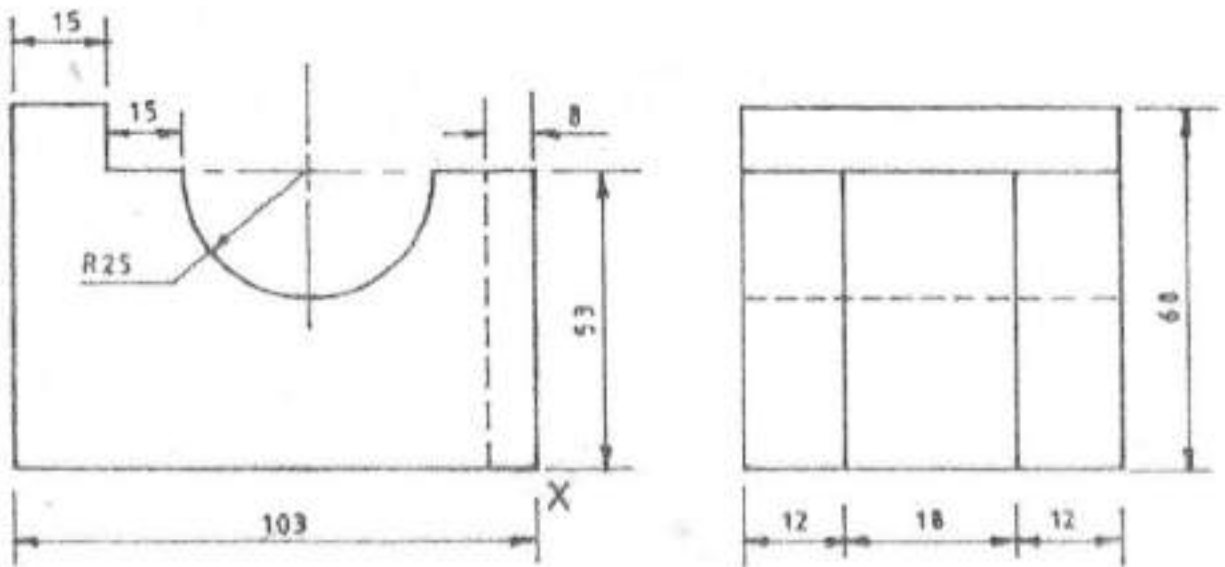

Fig. 2

3. Figure 3 shows a truncated hexagonal prism. Draw the given view and the following:
- a plan,
 - the true shape;
 - the surface development.

(20 marks)

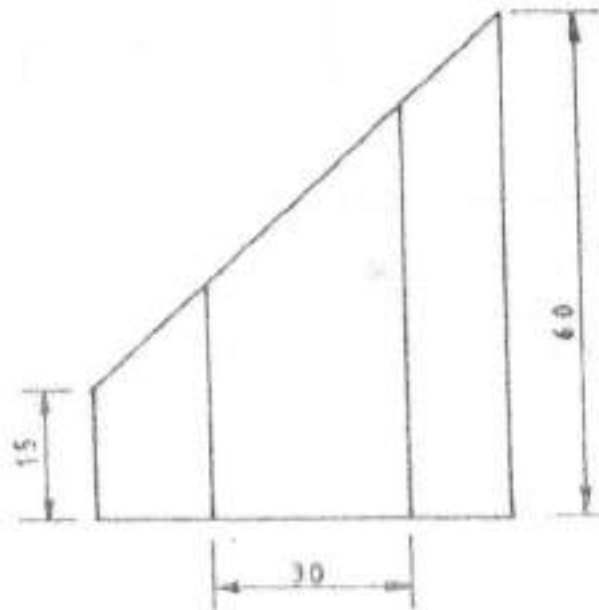

Fig. 3

4. (a) Figure 4, shows a C-wrench. Using correct geometrical constructions, draw the given view to scale. (10 marks)

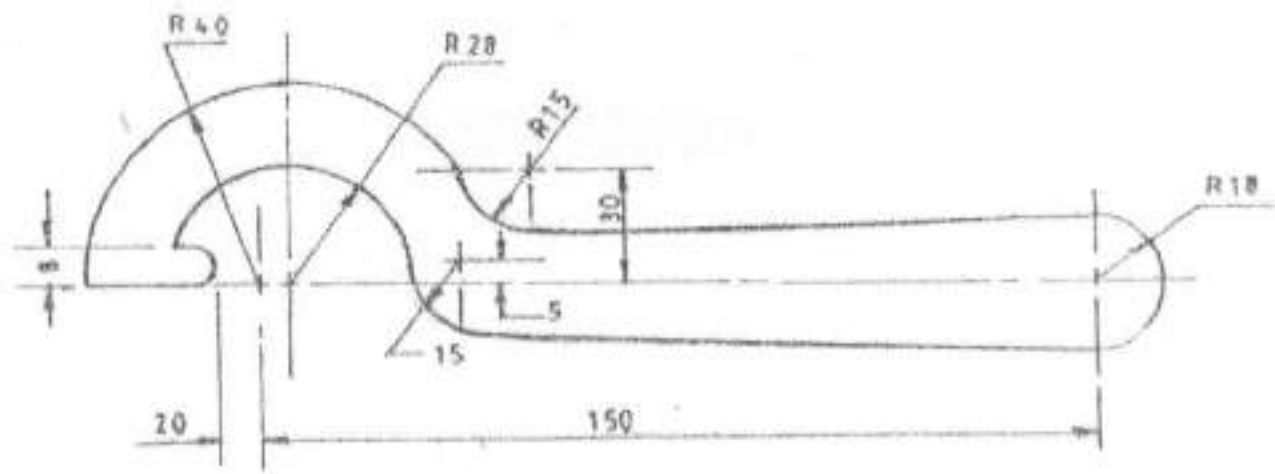

Fig. 4

- (b) Two circles A and B have radii 50 mm and 38 mm respectively. Construct internal and external tangents if the distance between their centres is 150 mm. (10 marks)

5. (a) Use free hand to sketch the following hand tools:

- (i) hacksaw;
- (ii) long nose pliers;
- (iii) combination pliers;
- (iv) side cutter;
- (v) star screw driver.

(15 marks)

(b) Draw the electronic symbols for the following:

- (i) transformer;
- (ii) microphone;
- (iii) NPN transistor;
- (iv) variable resistor;
- (v) zener diode.

(5 marks)

6. Figure 5 shows the layout of a direct on line starter for a three phase motor. Draw a circuit diagram for control on power circuit for the motor.

(20 marks)

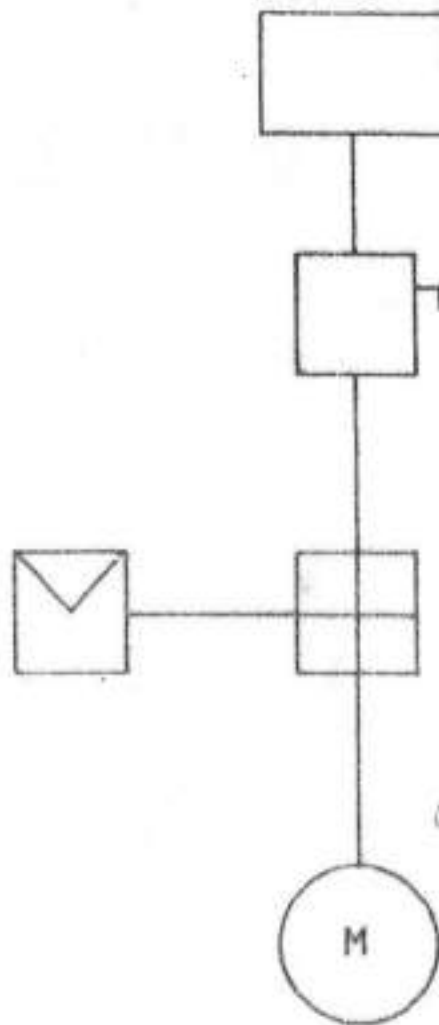

Fig. 5

7. Figure 6 shows the ground plan of a floor layout for a three bedroomed house. Make a suitable design for lighting and power points for the installation. Use appropriate architectural symbols and draw a key to describe the symbols used. (20 marks)

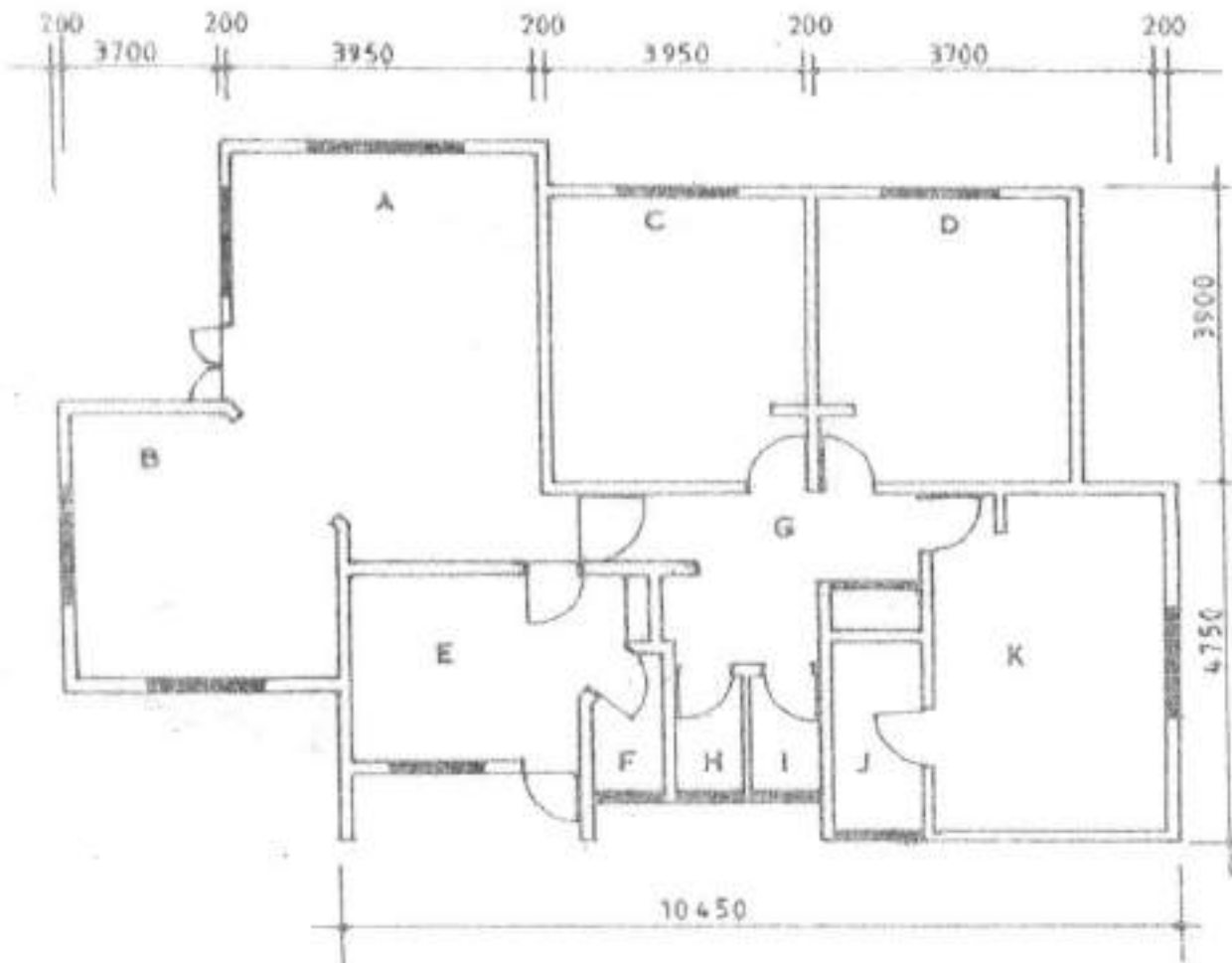

Fig.6

KEY:

- | | | | |
|---|--------------|---|----------------|
| A | SITTING ROOM | H | TOILET |
| B | DINING | I | BATHROOM |
| C | BEDROOM 1 | J | BATHROOM |
| D | BEDROOM 2 | K | MASTER BEDROOM |
| E | KITCHEN | | |
| F | STORE | | |
| G | CORRIDOR | | |

8. Figure 7 shows a bracket. Draw the full size of the following in 1st angle projection,

- (a) sectional front elevation on X-X;
- (b) a sectional end elevation on Y-Y;
- (c) a plan in the direction of arrow P.

(20 marks)

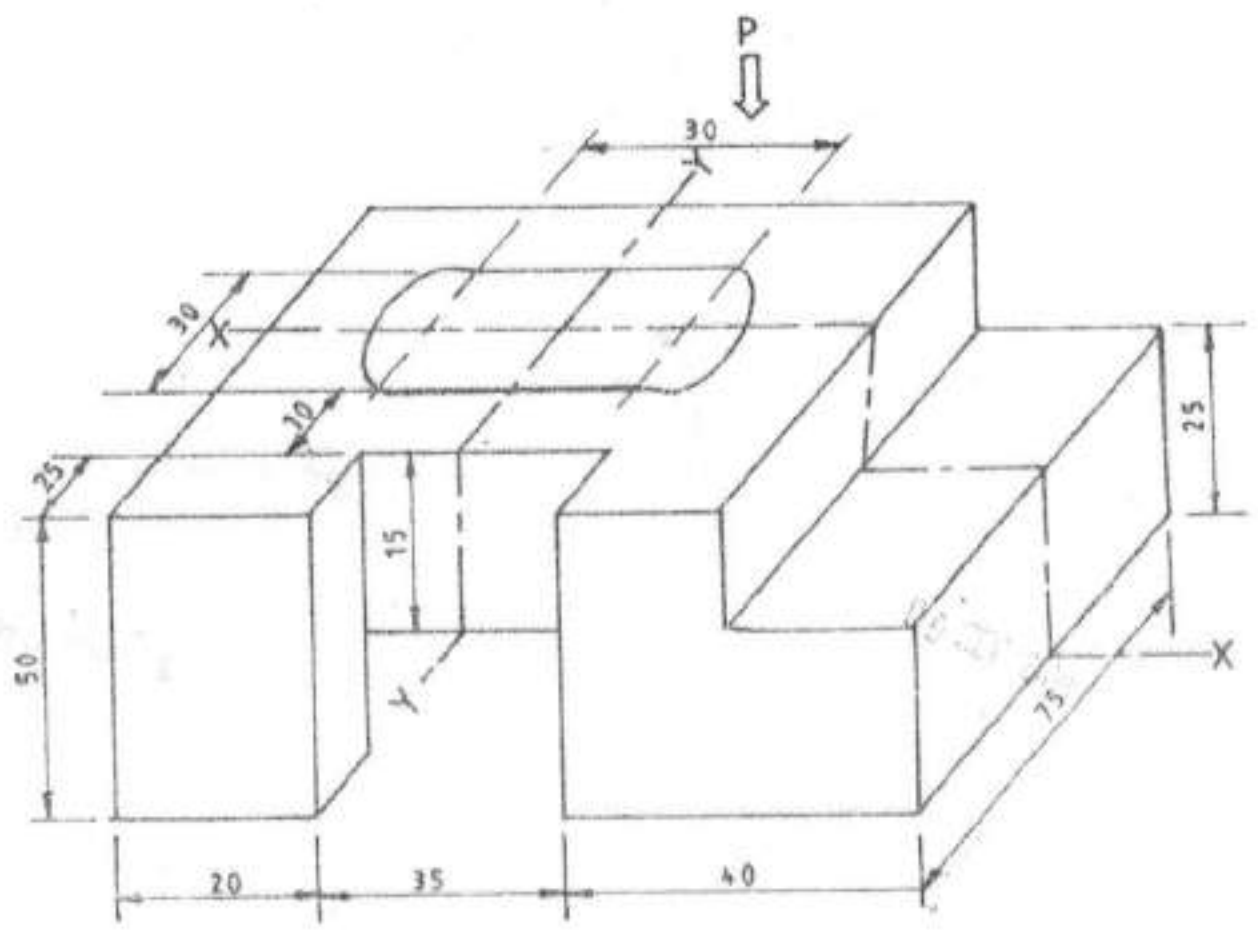

Fig. 7