

## SECTION A

Answer any **THREE** questions from this section.

1. (a) List any **three**:
- (i) types of electrical hazards;
  - (ii) effects of exposure to hazardous substances.
- (6 marks)
- (b) Explain how the following are used to minimize electrical hazards:
- (i) double insulation;
  - (ii) earthing;
  - (iii) safe voltages.
- (6 marks)
- (c) With regard to the Factory's Act, state any **two** safety precautions for each of the following:
- (i) machinery;
  - (ii) first aid;
  - (iii) fire;
  - (iv) movement at the place of work.
- (8 marks)
2. (a) Define the following terms with reference to engineering materials:
- (i) hardness;
  - (ii) corrosion resistance;
  - (iii) toughness.
- (6 marks)
- (b) State:
- (i) the composition of a ferrous metal;
  - (ii) any **two** examples of non-ferrous metals.
- (4 marks)
- (c) Describe the following processes used in finishes and decorations:
- (i) engineering;
  - (ii) etching.
- (4 marks)
- (d) Outline the process of 'electroplating'.
- (6 marks)

3. (a) Define the following terms with reference to workshop measurements:
- (i) limits;
  - (ii) tolerance. (2 marks)
- (b) Explain the need for marking out a workpiece and state any **two** tools used. (4 marks)
- (c) Describe the following techniques used to mark out a workpiece:
- (i) scribing;
  - (ii) centre punching. (4 marks)
- (d) Draw and label the following instruments:
- (i) vernier callipers;
  - (ii) vernier height gauge. (10 marks)
4. (a) (i) Table 1 shows series of standard wire gauge (SWG) and the corresponding thickness for sheet metals.

**Table 1**

Standard Wire Gauge (SWG)	Thickness (mm)
10	3.2
12	-
-	2.0
16	-
-	1.2
19	1.0
20	-

Fill in the corresponding values in the table.

- (ii) A 19 SWG sheet metal is required to construct a cylinder with an outside diameter of 150 mm. Determine the length of the square sheet metal required. (9 marks)

- (b) Explain the function of each of the following parts of a drilling machine:
- (i) pillar;
  - (ii) spindle;
  - (iii) handwheel.
- (3 marks)
- (c) Describe the following methods of joining metals:
- (i) oxy-acetylene welding;
  - (ii) arc welding.
- (4 marks)
- (d) Distinguish between 'Three-Jaw Self Centering Scroll' and 'Four Jaw independent chucks' used to hold workpieces in a centre lathe machine.
- (4 marks)

**SECTION B**

*Answer any TWO questions from this section*

5. Figure 1 shows a bracket. Draw full size in 1<sup>st</sup> angle projection the following views:

- (a) front elevation in the direction of arrow F;
- (b) end elevation in the direction of arrow E;
- (c) plan in the direction of arrow P.

Insert six major dimensions.

(20 marks)

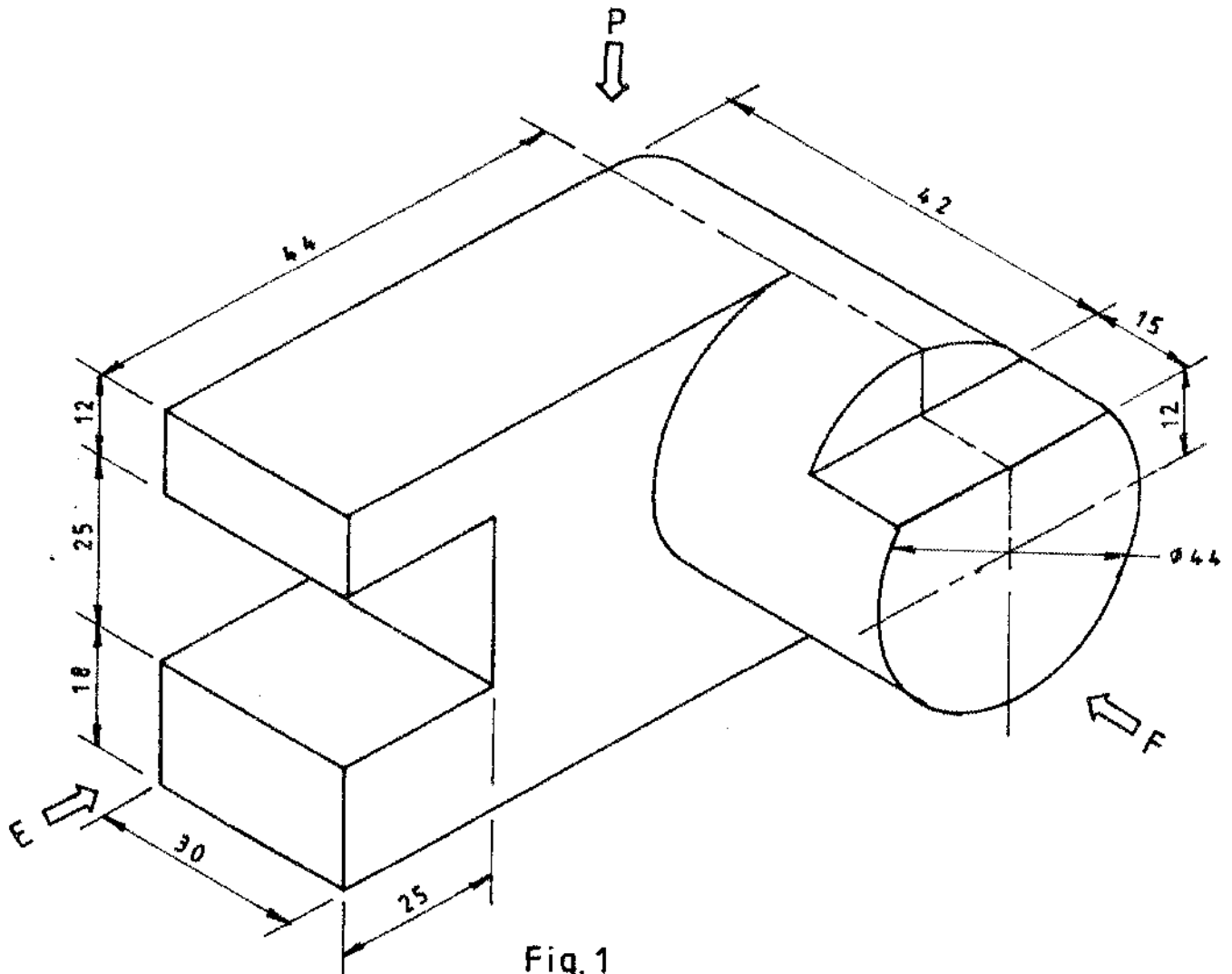

Fig. 1

6. Figure 2 shows two views of a solid drawn in 1<sup>st</sup> angle projection. Draw an isometric view of the object making corner N the lowest. (20 marks)

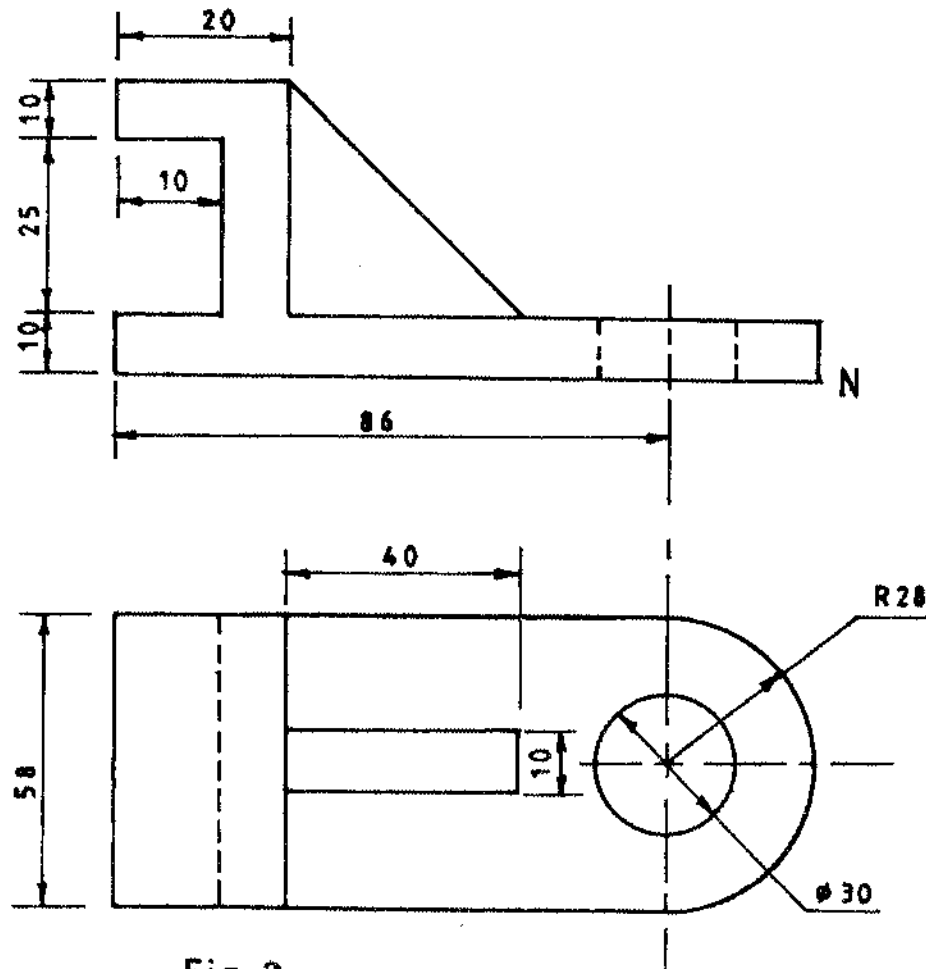

Fig. 2

7. Figure 3 shows a truncated cone. Draw the given view and add the following:

- (i) the plan;
- (ii) true shape;
- (iii) the development of the cone.

(20 marks)

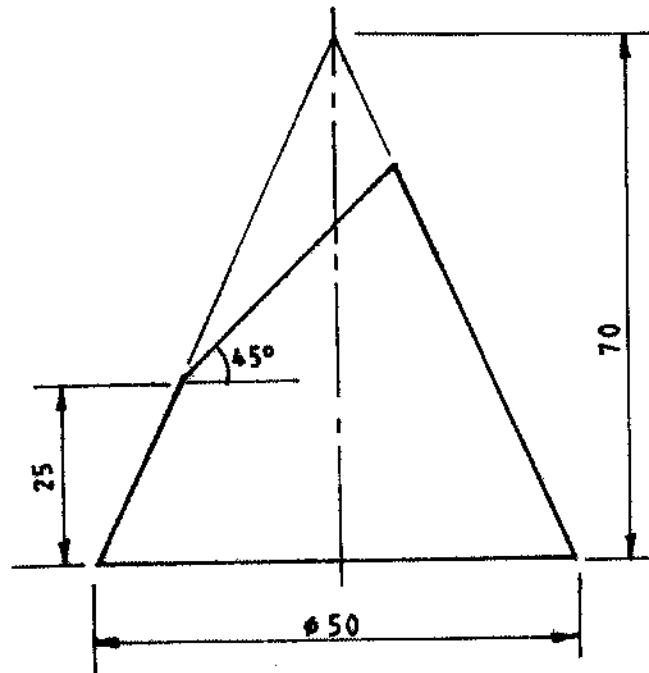

Fig. 3

8. (a) Draw free hand sketches of the following hand tools:

- (i) hacksaw;
- (ii) side cutter;
- (iii) flat screw driver;
- (iv) flat file;
- (v) tape measure.

(15 marks)

(b) Draw a regular hexagon given that the length across the flats is 70 mm.

(5 marks)