

2601/104 2603/104

2602/104

ENGINEERING DRAWING,
MATERIALS, PROCESSES AND
WORKSHOP TECHNOLOGY

June/July 2016

Time: 3 hours



THE KENYA NATIONAL EXAMINATIONS COUNCIL

DIPLOMA IN ELECTRICAL AND ELECTRONIC ENGINEERING
(POWER OPTION)
(TELECOMMUNICATION OPTION)
(INSTRUMENTATION OPTION)

MODULE I

ENGINEERING DRAWING, MATERIALS,
PROCESSES AND WORKSHOP TECHNOLOGY

3 hours

INSTRUCTIONS TO CANDIDATES

You should have the following for this examination:

Answer booklet;

Mathematical table/Scientific calculator;

Drawing paper A3.

This paper consists of TWO sections; A and B.

Answer THREE questions in section A, and TWO questions from section B.

Maximum marks for each part of a question are indicated.

Candidates should answer the questions in English.

This paper consists of 6 printed pages.

Candidates should check the question paper to ascertain that all the pages are printed as indicated and that no questions are missing.

SECTION A

Answer any **THREE** questions in this section

1. (a) State **two**:
- (i) causes of accidents in a workshop;
 - (ii) safety measures to be observed to prevent accidents in a workshop. (4 marks)
- (b) Outline the procedure for mouth to mouth method of artificial respiration to rescue an unconscious victim of an electric shock. (6 marks)
- (c) Explain the following properties of engineering materials:
- (i) ductility;
 - (ii) malleability. (4 marks)
- (d) With aid of a labelled diagram, explain the process of electroplating a workpiece. (6 marks)
2. (a) Describe the following marking out tools in an engineering workshop:
- (i) scriber;
 - (ii) engineer's square. (6 marks)
- (b) State **three** reasons for marking out a piece of metal before cutting and filing. (3 marks)
- (c) Define the term tolerance as used in measurements. (3 marks)
- (d) (i) Sketch and label a micrometer screw gauge.
(ii) State **two** functions of a micrometer screw gauge. (8 marks)
3. (a) State **two**:
- (i) categories of solders;
 - (ii) requirements of a good soldering flux. (4 marks)
- (b) Describe the gas cylinders used for oxy-acetylene welding gases. (6 marks)
- (c) State **two**:
- (i) functions of washers;
 - (ii) ways a rivet joint may fail. (4 marks)

- (d) Sketch the following self-secured joints:
- (i) paned-down joint;
 - (ii) grooved seam;
 - (iii) knocked-up bottom joint. (6 marks)
4. (a) List **three**:
- (i) metals used in sheet metal work;
 - (ii) products made from sheet metal. (6 marks)
- (b) Distinguish between a seam and an edge as used in sheet metal work. (4 marks)
- (c) Explain the following lathe machine operations:
- (i) facing;
 - (ii) knurling. (6 marks)
- (d) Sketch a labelled diagram of a twist drill bit. (4 marks)

SECTION B

Answer any TWO questions from this section

5. Figure 1 shows an elevation of a truncated cone. Draw the given elevation and complete the following:
- (a) plan;
 - (b) end elevation in the direction of arrow E;
 - (c) true shape at X - X. (20 marks)

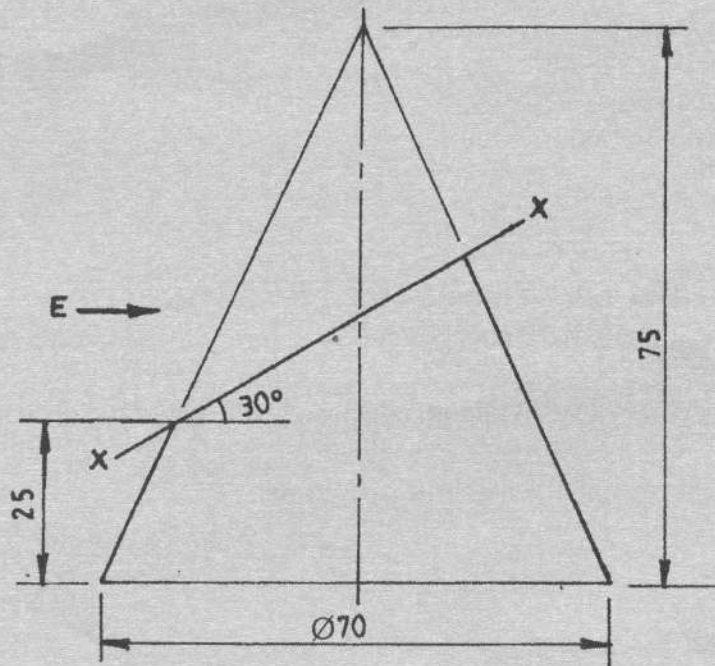

Fig. 1

6. Figure 2 shows two views of a holding down clamp. Draw the clamp full size in oblique cabin projection with face A as the lowest. (20 marks)

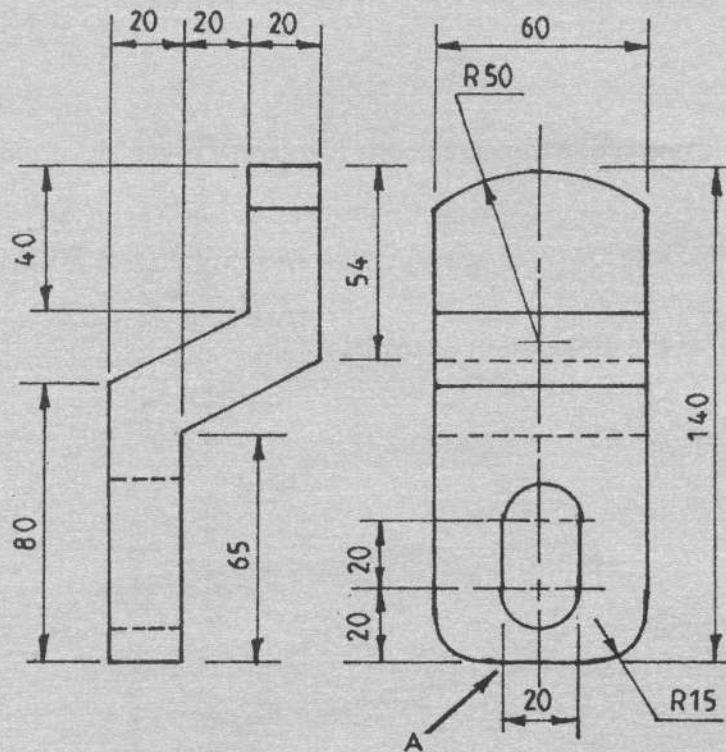

Fig. 2

7. Figure 3 shows the elevation of two dissimilar pipes meeting at an angle. Draw the elevation and complete the following using third angle projection:

- (a) the plan;
- (b) curve of intersection;
- (c) development of both pipes.

(20 marks)

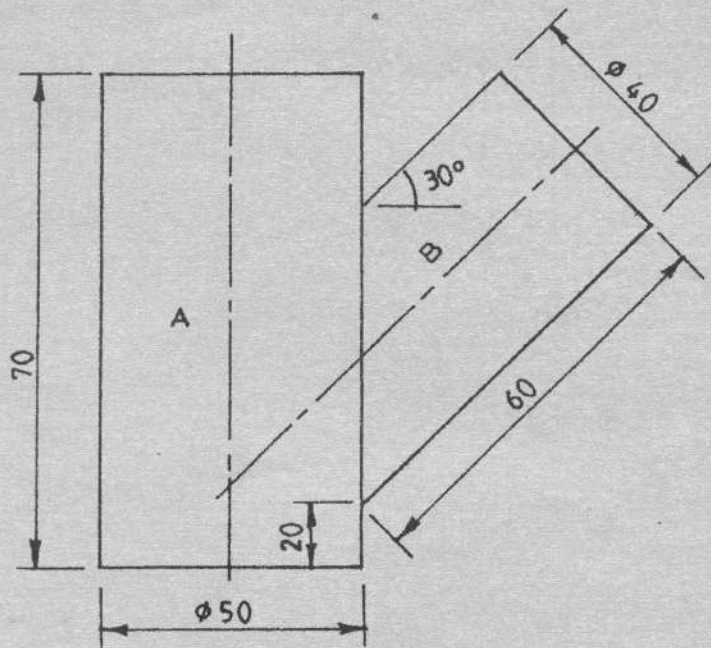

Fig. 3

8. Figure 4 shows a pictorial view of a block. Draw full size in first angle projection the following:

- (a) plan in the direction of arrow P;
- (b) front elevation in the direction of arrow F;
- (c) end elevation in the direction of arrow E.

Insert six major dimensions.

(20 marks)

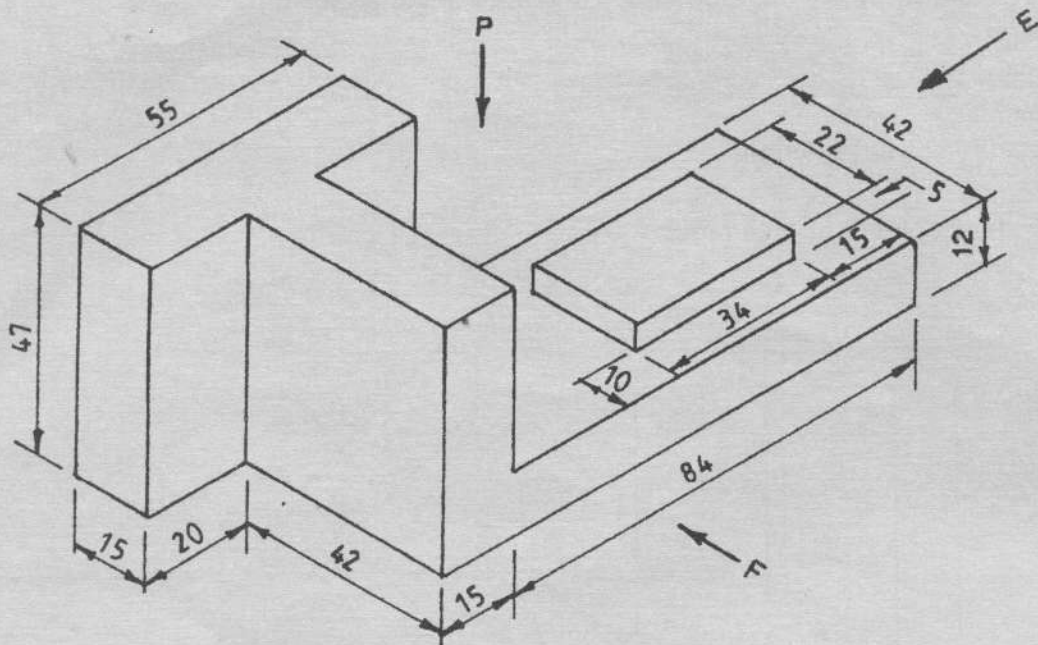

Fig. 4

THIS IS THE LAST PRINTED PAGE.