

Name: _____ Index No. _____

2521/105 2602/106

2601/106 2603/106

Candidate's Signature: _____

**ELECTRICAL MEASUREMENTS AND
ANALOGUE ELECTRONICS I**

Date: _____

Oct./ Nov. 2015

Time: 3 hours

**THE KENYA NATIONAL EXAMINATIONS COUNCIL**

**DIPLOMA IN ELECTRICAL AND ELECTRONIC ENGINEERING
(POWER OPTION)
(TELECOMMUNICATION OPTION)
(INSTRUMENTATION OPTION)
MODULE I**

ELECTRICAL MEASUREMENTS AND ANALOGUE ELECTRONICS I**3 hours****INSTRUCTIONS TO CANDIDATES***Write your name and index number in the spaces provided above.**Sign and write the date of the examination in the spaces provided above.**You should have a drawing instruments and Scientific calculator/Mathematical tables for this examination.**This paper consists of **TWO** sections; **A** and **B**.**Answer any **THREE** questions from section **A** and **TWO** questions from section **B** in the spaces provided in this question paper.**All questions carry equal marks.**Maximum marks for each part of a question are as shown.**Do **NOT** remove any pages from this booklet.**Candidates should answer the questions in English.***For Examiner's Use Only**

Section	Question	Maximum Score	Candidate's Score
A		20	
		20	
		20	
B		20	
		20	
TOTAL SCORE		100	

This paper consists of 24 printed pages**Candidates should check the question paper to ascertain that all the pages are printed as indicated and that no questions are missing.**

SECTION A: ELECTRICAL MEASUREMENTS

Answer any **THREE** questions from this section.

1. (a) Define each of the following units, giving an example in each case:

- (i) absolute;
 (ii) fundamental;
 (iii) derived.

(6 marks)

(b) Derive the dimensions of the following quantities in the LMTI system:

- (i) potential difference;
 (ii) magnetic flux density.

(8 marks)

(c) The following equation was obtained from the measurement of resistance in an electrical system. Show that it is dimensionally correct using e.m.u system of units.

$$r = \frac{R \omega^2 M_1 M_2}{R^2 + \omega^2 L^2}$$

where r, R = resistances
 M_1 and M_2 = mutual inductance
 L = self inductance
 ω = angular frequency.

(6 marks)

2. (a) (i) Describe each of the following errors:

- I. instrumental; ✓
 II. environmental; ✓
 III. observational. ✓

(ii) State any **one** method used to minimize each of the errors in a(i).

(9 marks)

(b) The resistance of an unknown resistor, R_4 , determined by the wheatstone bridge is

given by the expression $R_4 = \frac{R_1 R_2}{R_3}$
 where limiting values of the resistances are:

$$R_1 = 500 \Omega \pm 1\%$$

$$R_2 = 615 \Omega \pm 1\%$$

$$R_3 = 100 \Omega \pm 0.5\%$$

Determine the following for the unknown resistance, R_4 :

- (i) nominal value;
 (ii) limiting error;
 (iii) limiting values.

(6 marks)

$$M = 1 - e^{-\frac{1}{m} t t R}$$

(c) A voltmeter having a sensitivity of $1000 \Omega/V$ reads $100 V$ on its $150 V$ scale when connected across an unknown resistor in series with a milliammeter. When the milliammeter reads $5 mA$, determine the:

- (i) apparent resistance of the unknown resistor;
- (ii) actual resistance of the unknown resistor.

(5 marks)

3. (a) State any **four** advantages of the digital instruments over the analog instruments.

(4 marks)

(b) Explain the importance of a circuit diagram in the servicing and maintenance of an electrical equipment.

(4 marks)

(c) (i) Figure 1 shows a balanced Hay's bridge. Determine the value of the:

- I. resistor R_1 ;
- II. inductor L_1 .

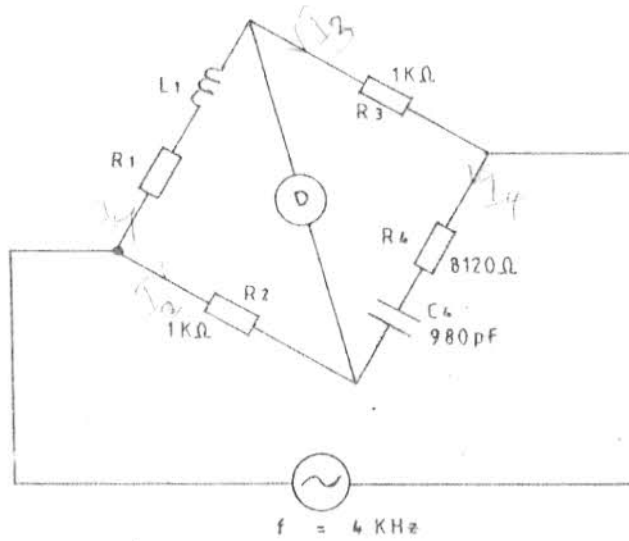

Fig. 1

(ii) State any **one** advantage of using the Hay's bridge over the Maxwell's bridge for the measurement of inductance of a coil.

(12 marks)

4. (a) Define the following with respect to electrical equipment:

- (i) reliability; ✓
- (ii) failure; ✓
- (iii) availability; ✓

(3 marks)

- (b) Outline the steps to be followed in soldering. (5 marks)
- (c) Sketch the bath tab distribution curve and explain its shape. (8 marks)
- (d) State any **two** common faults in each of the following electronic components:
- capacitors;
 - P-n junction diodes.
- (4 marks)

5. (a) (i) State any **one** possible cause for the following faults in a d.c machine:
- failure to start completely;
 - excessive sparking at the brushes;
 - vibrations and pounding noises.
- (ii) State any **three** merits of preventive maintenance. (6 marks)
- (b) Outline the procedure for overhauling and assembling an electric motor for repair. (8 marks)
- (c) Figure 2 shows a transistor amplifier. Explain the effect for each of the following faults:
- base-emitter short circuit;
 - resistor R_1 open circuit.
- (6 marks)

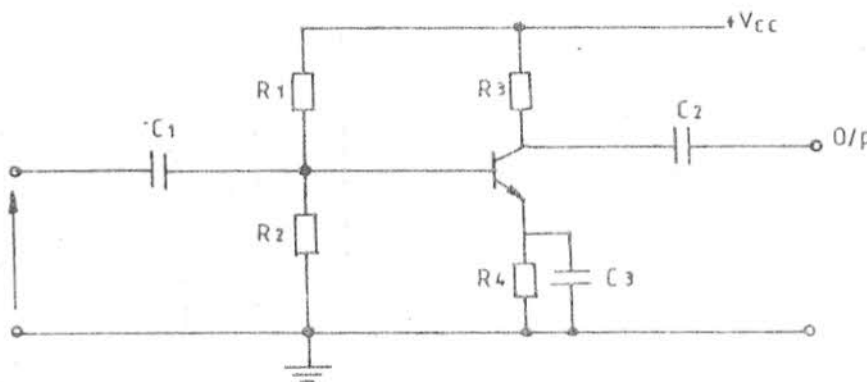

Fig. 2

8-10, 5-11

SECTION B: ANALOGUE ELECTRONICS I

Answer any **TWO** questions from this section.

6. (a) Explain avalanche breakdown in semi conductor diodes. (4 marks)
- (b) An a.c source of supply of 230 Vrms is applied to a half wave rectification circuit through a transformer whose turns ratio is 10:1. The rectifier supplies a load of 800 Ω . Assume diode resistance is 10 Ω . Determine the:
- the rms value of voltage that appears across the secondary;
 - maximum voltage that appears across the secondary;
 - maximum current in the load;
 - maximum load current.

(8 marks)

- (c) A zener diode has a reverse break down voltage of 5.8 V and after this, it can be considered as a linear resistance of 10 Ω . It is to be used in a voltage stabilization circuit to stabilize the load voltage at 6 V from 12 V supply. The load resistance is 2 k Ω . Determine the value of the required series current limiting resistor.

(8 marks)

7. (a) State any **two** advantages of the JFETs over the BJT's. (2 marks)
- (b) Define each of the following with respect to field effect transistor:
- pinch-off voltage (V_p);
 - gate source cut off voltage ($V_{GSS\ off}$).

(2 marks)

- (c) The readings in table 1 were obtained during an experiment on JFET.

Table 1

V_{GS}	0v	0v	-2v
V_{DS}	7v	15v	15v
I_d	10mA	10.25 mA	9.65 mA

Using the data, determine the:

- a.c drain resistance;
- transconductance;
- amplification factor.

(6 marks)

- (d) (i) For a BJT show that $\beta = \frac{\alpha}{1 - \alpha}$ where β = common emitter current gain;
 α = common-base current gain.
- (ii) The figure 3 shows a transistor amplifier biased by the voltage divider bias method. Determine the value of the:
- I. current through resistor R_2 ;
 - II. base voltage.

(10 marks)

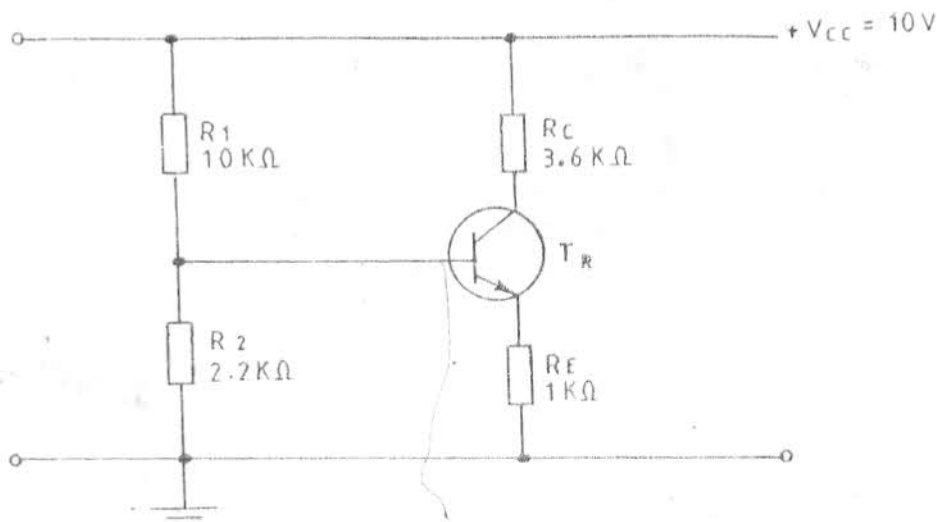

Fig. 3

8. (a) Define the following with respect to thermionic emission:

- (i) space charge;
- (ii) work function.

(2 marks)

- (b) Figure 4 shows a block diagram of a cathode ray oscilloscope (CRO). Name the parts labelled 1 to 6 and state the function of each part. (12 marks)

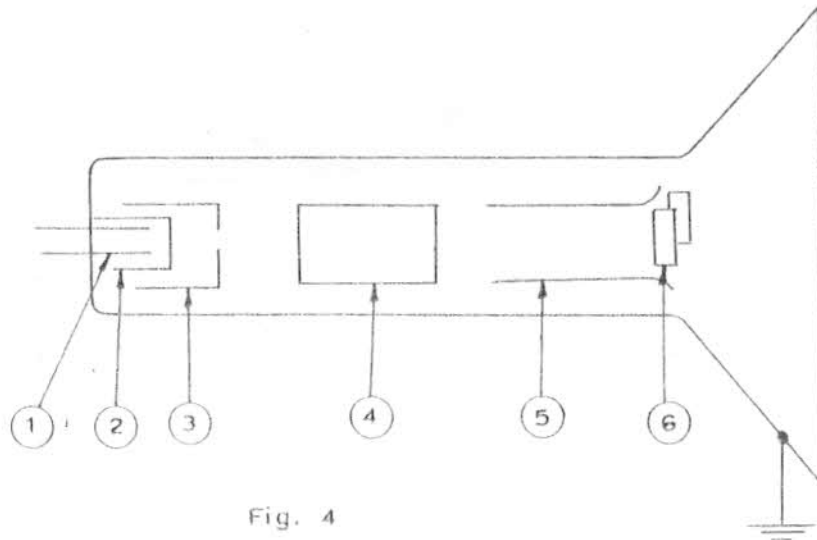

Fig. 4

(c) Figure 5 shows an oscilloscope display of a sinusoidal waveform. The vertical scale is set at 10 V/cm while the time scale is set at 20 ms/cm. Determine the:

- (i) peak value of the voltage;
- (ii) frequency of the wave.

(6 marks)

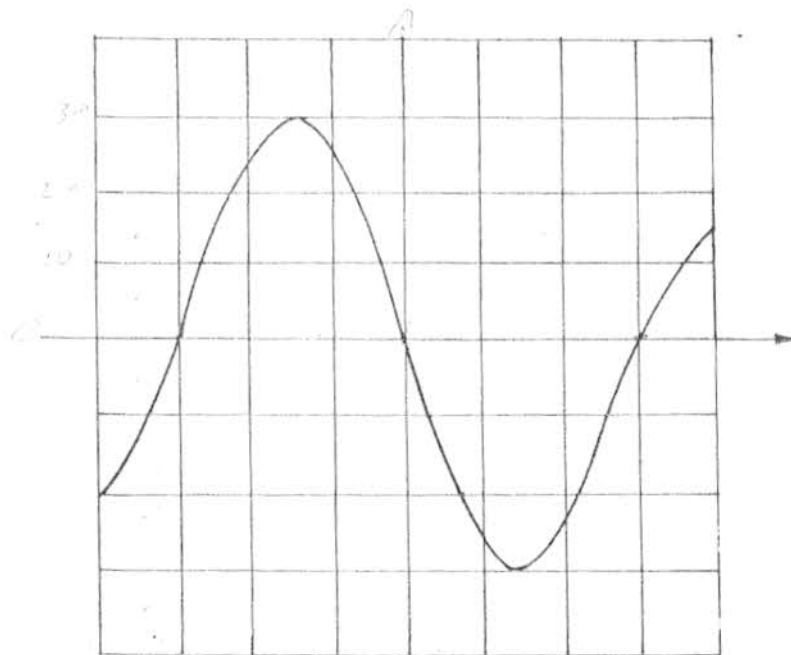

Fig. 5