

071306T4EIN

Electrical Installation Level 6

ENG/OS/EIT/CR/05/6/A

Perform commissioning of electrical systems.

July/August 2023



**TVET CURRICULUM DEVELOPMENT, ASSESSMENT AND CERTIFICATION
COUNCIL (TVET CDACC)**

OBSERVATION CHECKLIST

INSTRUCTIONS TO THE ASSESSOR

1. You are required to mark the practical as the candidate perform the tasks.
2. You are required to take video clips at critical points.
3. Ensure the candidate has a name tag and registration code at the back and front.

OBSERVATION CHECKLIST			
Candidate's name & Registration No.			
Assessor's name & Reg. code			
Unit(s) of Competency			
Venue of Assessment			
Date of assessment			
Items to be evaluated: <i>(Award appropriate marks for each item evaluated)</i>	Marks available	Marks obtained	Comments
OBSERVATION CHECKLIST			
1. Wore safety clothing			
i. Safety boots <i>(Award 1 or 0)</i>	1		
ii. Dust coat <i>(Award 1 or 0)</i>	1		
2. handled tools Properly <i>(Award 2 or 0)</i>	2		
3. Observed color code <i>(Award 1 or 0)</i>	1		
Sub total	5		
TASK 1			
4. Dimensioned accurately $\pm 2mm$ <i>(Award any 4)</i>	4		
5. Fixed components (firm and level) <i>(Award any ½ X 4)</i>	2		
6. Fixed cables (straight and flat on surface)			
i. Vertical <i>(Award any ½ x 2)</i>	1		
ii. Horizontal <i>(Award any ½ x 2)</i>	1		
iii. Correctly terminated <i>(Award any ½ x 4)</i>	2		

7. Distribution of cable clips; i. Uniform and equally distributed. (Award 1 or 0)	1		
ii. Facing one side. (Award 2 or 0)	2		
8. Components on the same level. (Award ½ x 4)	2		
Sub total	15		
TASK 2			
9. Performed the following test before commissioning. i. Continuity test ii. Polarity test (Award 2 marks each or 0)	2 2		
10. Correct circuit operation (Award 3 marks or 0)	3		
Sub total	7		
TASK 3			
11. Prepared a handover report; i. Information related to scope (Award 4 or 0) ii. Timelines (Award 4 or 0) iii. Budget (Award 4 or 0) iv. Challenges (Award 4 or 0) v. Deliverables (Award 4 or 0)	4 4 4 4 4		
Sub total	20		
TASK 4			
12. Drew wiring diagram as per layout diagram i. Correct sequence. (Award 5 or 0)	5 2		

ii. Colour coding. (Award 2 or 0)			
Sub total	7		
TASK 5			
13. Conducted end user training;(assess orally)			
i. User trained on the operation and functioning of the system. (Award 5 or 0)	5		
ii. User trained on routine checks as per the user manuals. (Award 5 or 0)	5		
Sub total	10		
GRAND TOTAL	64		
$\frac{x}{64} \times 100$			
The candidate was found to be: (Please tick (✓) as appropriate)			
Competent <input type="checkbox"/>	—	Not yet competent <input type="checkbox"/>	
<i>(The candidate is competent if s/he gets scores 50% of marks with items)</i>			
Feedback from candidate:			
Feedback to candidate:			
Candidate's signature:	Date		
Assessor's signature:	Date		

WIRING DIAGRAMS

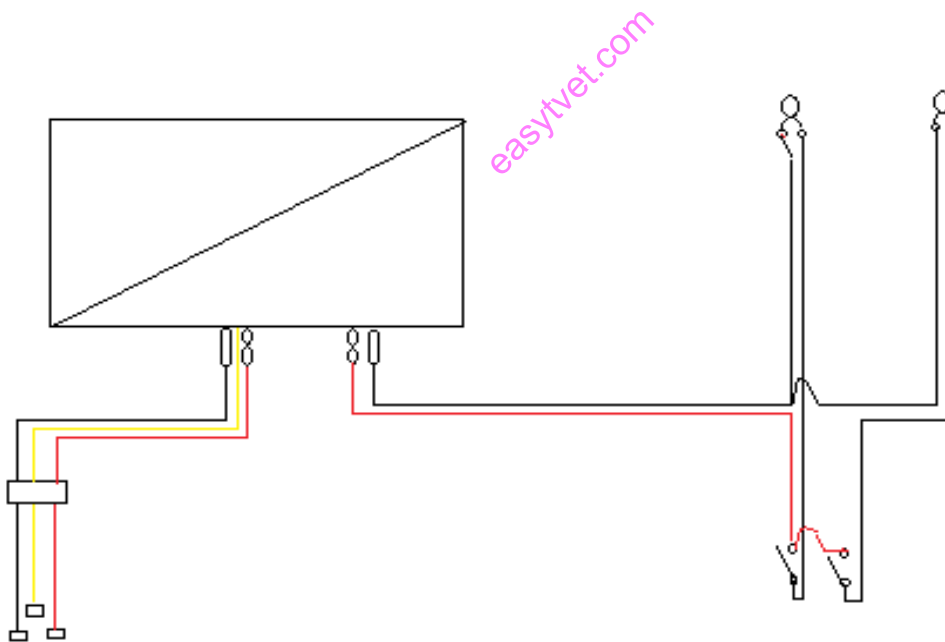
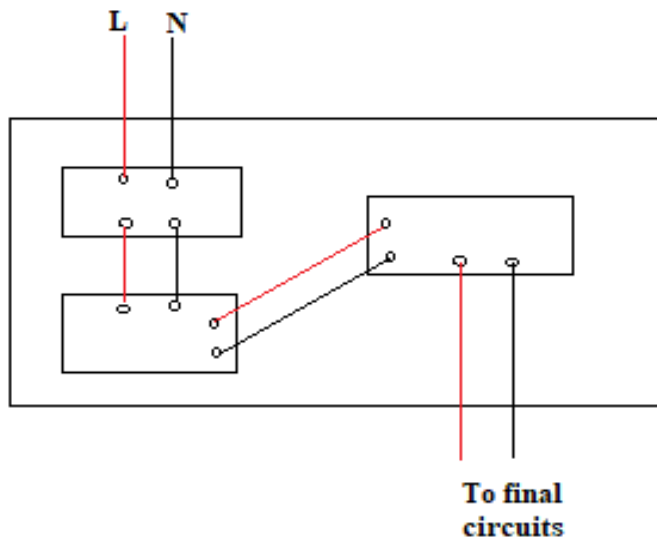

THIS IS THE LAST PRINTED PAGE.